

REF. NO.	PART NO.	PART NAME	QTY.
1.	E27-3110	TORQUE LINK ARM (MAKE FROM E27-3120)	1
2.	E27-1160	5/16 MALE ROD END	4
3.	E27-3160	TORQUE LINK GUSSET .125 4130 STL	2
4.	E27-1240	RUBBER INSERT	1
5.	E00-2513	BOLT 5/16 X 1-1/2	1
6.	E12-3190	(REF. P/N) TORQUE LINK BRACKET	1
7.	E27-6160	ALUMINUM INSERT	1
8.	E27-3100	TORQUE LINK ATTACHMENT TUBE	1
9.	E27-1200	RUBBER WASHER 1/8" THICK	2
10.	E00-2517	BOLT 5/16 X 2	1
11.	E27-6120	BUSHING (MAKE FROM E27-3120)	1
12.	E27-5100	CLUTCH ARM CASTING	1
13.	E27-3120	"T" HANDLE	1
14.	E27-3130	CLUTCH ENGAGEMENT HANDLE	1
15.	E24-5100	UPPER ENGINE MOUNT CUP	1
16.	E24-1611	RUBBER STRIP	1
17.	E00-4100	1/8 WASHER	2
18.	E00-6206	1/8 X 1/4 ALUMINUM POP RIVET	2
19.	E24-5110	UPPER FRAME CLEVIS CASTING	1
20.	E27-3150	IDLER PULLEY BRACE (FROM E27-3120)	1
21.	E27-3170	IDLER ARM WELDMENT	1
22.	E27-3180	IDLER ARM BUSHING (FROM E27-3120)	1
23.	E27-6100	IDLER PULLEY ASSY	1
24.	E00-2522	BOLT 5/16 X 3	1
25.	E00-2525	BOLT 5/16 X 2-1/4 ALL THREAD	1
26.	E00-2416	BOLT 1/4 X 1-3/4	1
27.	E00-2531	BOLT 5/16 X 2-1/4	2
28.	E00-2524	BOLT 5/16 X 3-1/2	2
29.	E00-2514	BOLT 5/16 X 1-3/4	2
30.	E00-2508	BOLT 5/16 X 1-1/8	1
31.	E12-3230	(REF. P/N) CLUTCH PIVOT ARM BRACKET	1
32.	E00-6202	1/8 X 1/4 STEEL POP RIVET	2
33.	E27-6150	CLUTCH SPRING TUBE WELDMENT	1
34.	E27-6191	IDLER PULLEY SPACER	2
35.	E00-4700	1/2" WASHER	2
36.	E00-3700	1/2" FIBERLOCK NUT	1
37.	E00-2505	BOLT 5/16 X 7/8	2
38.	E27-1210	CLUTCH IDLER SPRING	2
39.	E27-2160	5/16 MALE ROD END, TEFLON	1
40.	E27-6131	CLUTCH TUBE PISTON	1

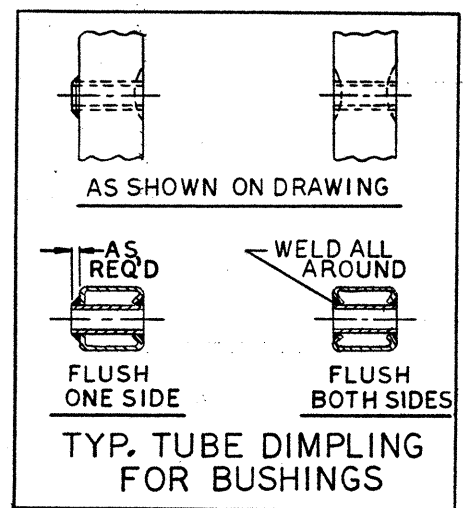

NOTE: THE SQUARE TUBING PORTION OF THE AIR FRAME IS REFERRED TO AS THE DRIVE MOUNT AREA.

ROTORWAY INTERNATIONAL  
PHOENIX, ARIZONA

SCALE: NONE	APPROVED: <i>[Signature]</i>	DRAWN BY: P. H.
DATE: 2-1-91	REVIEWED:	
ENGINE CLUTCH AND TORQUE LINK; DRIVE MOUNT AND UPPER ENGINE MOUNT		
DRAWING NUMBER: E27-2000		